

## Application of rapid prototyping and tooling technologies in development of cash-less fare-payment system

Electronic terminal (designed and manufactured by 4thWAY Ltd.), described in this case study, consists of several parts (Figure 1):

- Electronic system for non-contact identification and fare calculation
- Thermal printer for printing the receipt and travel info
- Housing for mechanical protection and interaction between the terminal and end-user



Figure 1: None-cash fare payment system

Housing consisted of three parts:

- Metal base frame for fastening the functional elements
- Plastic cover of the terminal
- Small movable door for paper replacement

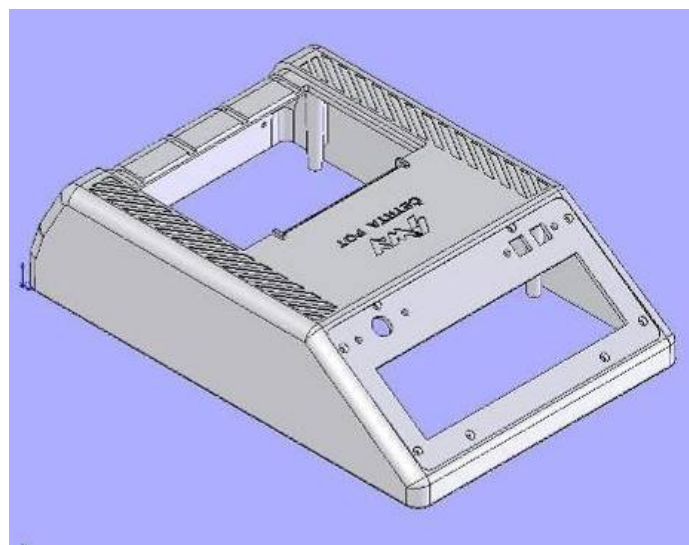

Figure 2: CAD model

The first step was the development of the functional prototype. CAD three-dimensional model was made according to the dimensions of internal electronic components (Figure 2). Outside visual look and control layout were also taken into consideration during the modeling.

The next step was the production of the physical prototype (Figure 3) by PolyJet™ rapid prototyping technology at Rapid Prototyping laboratory in the Faculty of Mechanical Engineering in Maribor. The PolyJet™ prototype was used for test-assembly of electronic components and testing of user control layout.



Figure 3: PolyJet™ prototype

The PolyJet™ prototypes were also used as patterns for manufacturing epoxy resin tools (ET Rapid Tooling) that were later used to produce a batch of 100 housings by RIM (Reaction Injection Molding) procedure. ET moulds and the first batch were produced by Modelarstvo Stanovnik ltd. (Figure 4).



Figure 4: ET Rapid tooling moulds

The batch series was used for testing the terminal design in real environment on public transport vehicles. This testing resulted in some minor changes of the design.

The design changes were implemented in the last phase of the project, when the series production tools were manufactured by Orodjarstvo Maks Pecnik ltd (Figure 5). In this phase the semi-automatic assembly system was also devised.



Figure 5: Final production tools

This project has clearly shown the advantages of using rapid prototyping technologies in early stages of new product development. The final estimate was made that shows 80% in lead-time reduction in comparison to conventional methods. All partners who participated in this project are members of RAPIMAN - Rapid Prototyping and Innovative Manufacturing Network.